

GRAND GRANTEES, SUBLIME SUBRECIPIENTS



2019 OLA–WLA CONFERENCE

April 19, 2019

Michael Achterman, Greta Bergquist, Ross Fuqua, and Maura Walsh

Agenda

- Welcome & Introductions
- Research & Writing
- Grant Management
- Coming Attractions



Welcome!



Why is your library or project worth funding?



Research & Writing



Research & Writing



THE OREGON
COMMUNITY
FOUNDATION

Here for Oregon. Here for Good.



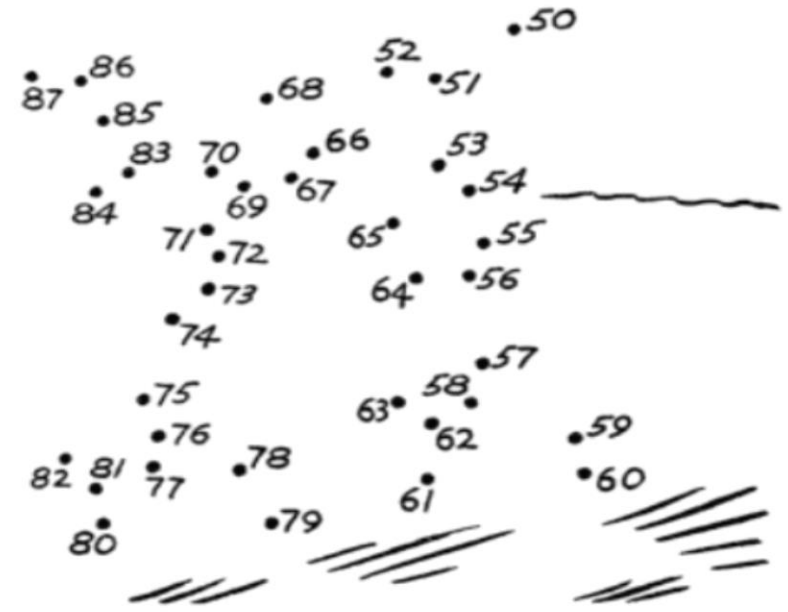
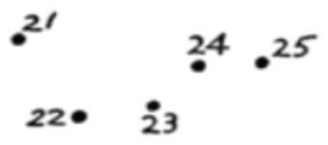
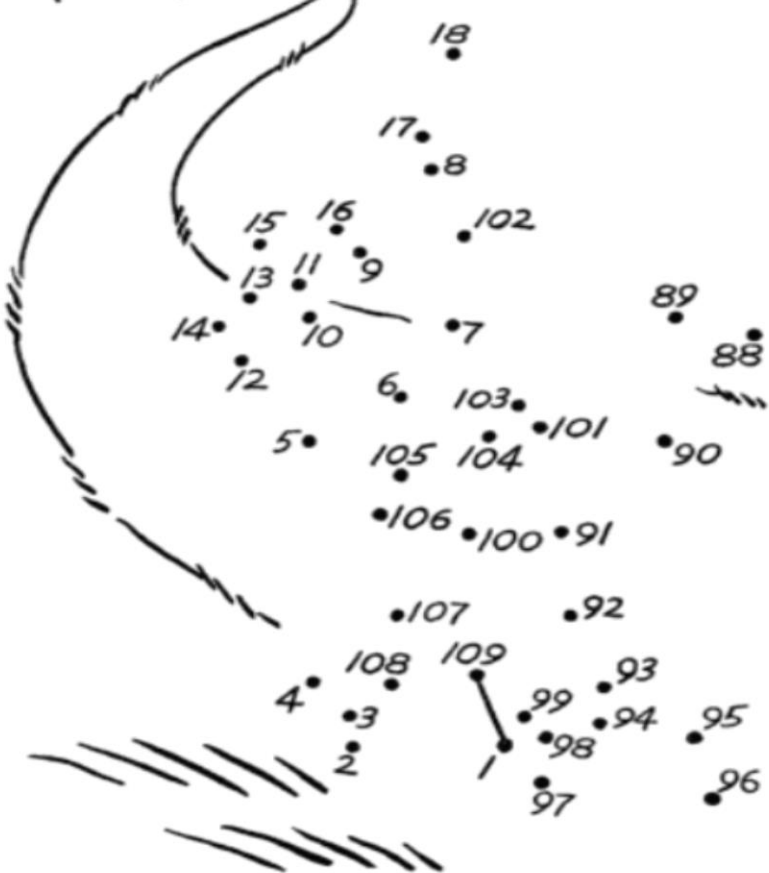

Research & Writing



INSTITUTE of
Museum and Library
SERVICES

LSTA
GRANTS

Need

Data

Plan

Impact



Charting the
UNKNOWN
TOGETHER

Research & Writing

- Find the right source of funding
- Talk to potential funding sources
- Balance data and storytelling with your narrative
- Make a compelling argument for your desired outcome

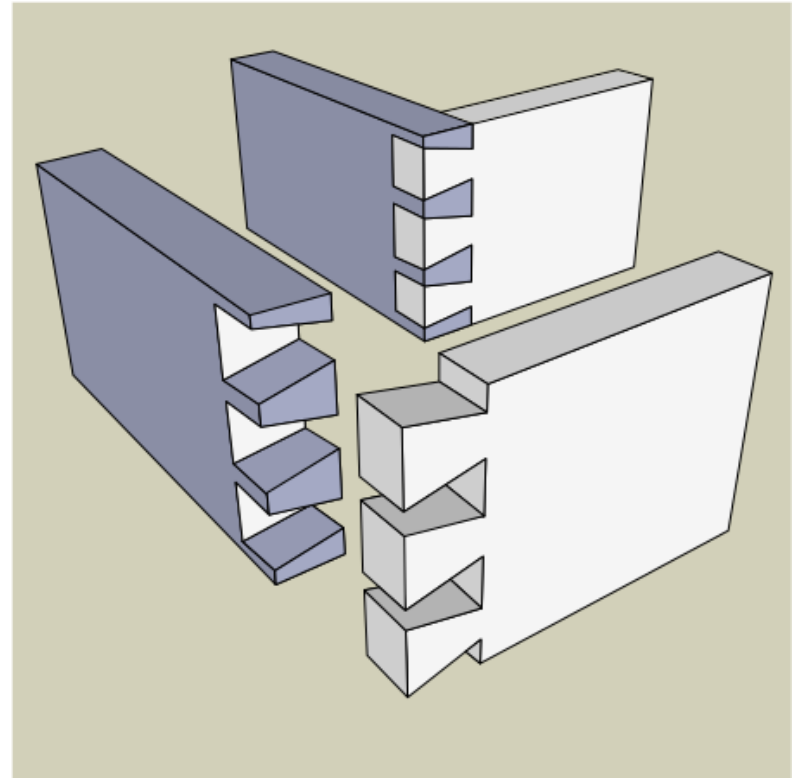

Joinery-throughdovetail.gif Duncan Tate [CC BY-SA 3.0
(<http://creativecommons.org/licenses/by-sa/3.0/>)]

S - T - R - E - T - C - H - !



Grant Management

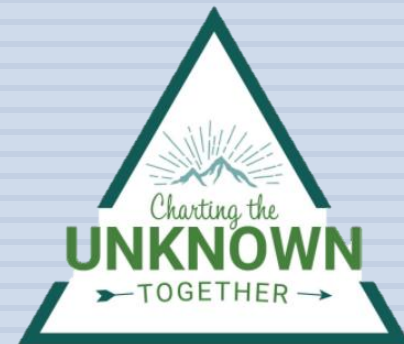

Grant Management



THE OREGON
COMMUNITY
FOUNDATION

Here for Oregon. Here for Good.



LSTA: The Triple Threat

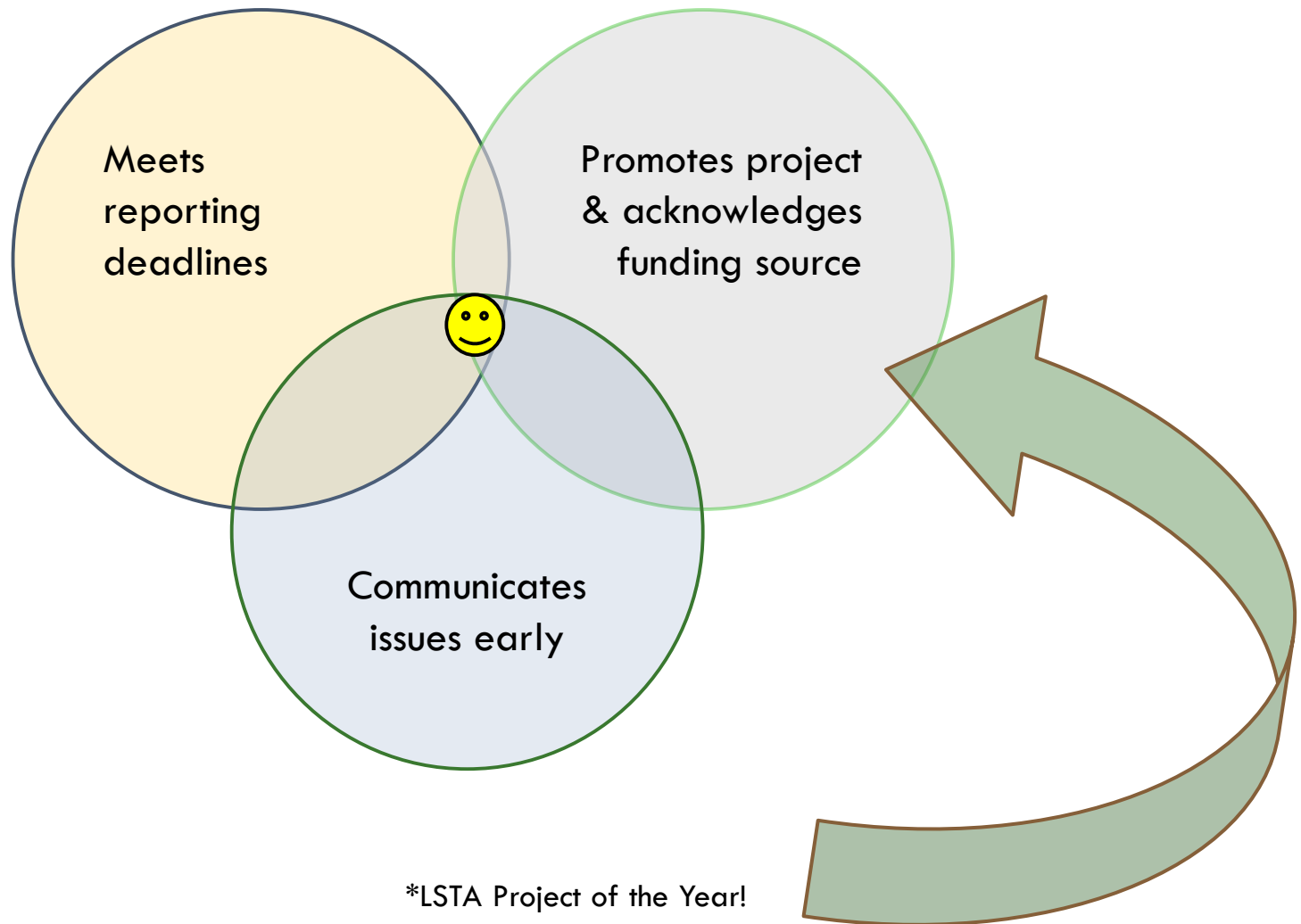

LSTA Grant Management

- Let us know how it's going
- Promote your work
- Calendar deadlines & milestones
- Acknowledge your funding source

Coming Attractions

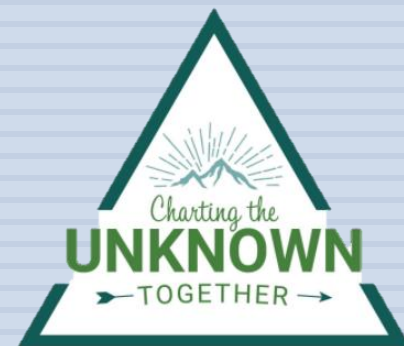

Coming Attractions – Oregon!



Coming Attractions – Oregon!

- Online grants management system
- More Professional Development / CE grants
- Prioritize projects to meet LSTA Program Goals
- Deep dive into LSTA Competitive Grants data
- Investigate questions about equity & access

Coming Attractions - Washington!

Professional Development Grants

For training at your library or sending staff to training events

BACK BY POPULAR DEMAND!

NEW VERSION

IMPROVED



Washington !

Letters of
Intent

Shark Tank



Wrapping up . . .



Questions?

**Thank you
for coming**



Contact

Greta Bergquist

Youth Services Consultant
503-378-2528

Ross Fuqua

Data & Federal Programs Consultant
503-378-5027



State Library
of Oregon

Michael Achterman

Program Officer
503-227-6846



THE OREGON
COMMUNITY
FOUNDATION

Here for Oregon. Here for Good.

Maura Walsh

Grant & Contracts Coordinator Lead
360-704-5246

Washington State Library

